

Z-15000

Low pressure type

自由型

●用途

使用目的:排気管等低圧配管の伸縮吸収

構造:ベローズの両端に端管およびフランジを溶接した構造。

●特長

最もスタンダードな伸縮継手です。

●フランジ規格

JIS5K、JIS10K、JPI

複式タイプも製作可能

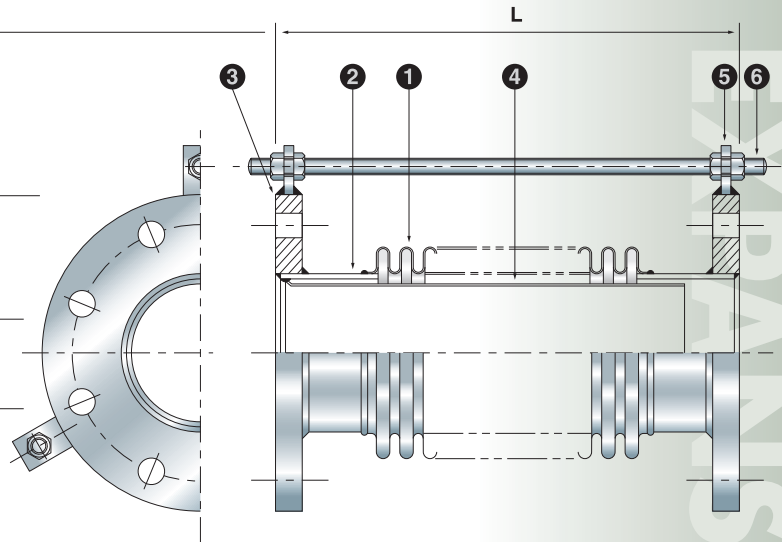

番号 No	部品名称 Name	材質 Material
1	ベローズ Bellows	SUS304 Stainless steel 304
2	端管 Pipe	SGP Carbon steel
3	フランジ Flange	SS400 Carbon steel
4	内筒 Inner pipe	SUS304 Stainless steel 304
5	ホルダー Holder	SS400 Carbon steel
6	セットボルト Setting bolt	SS400 Carbon steel

※ベローズ、金具素材の変更も可能です

※Other materials are also available on request.

●Applications

Purpose

Absorption of axial expansion and contraction on low-pressure piping, such as Exhaust piping.

Structure

Composing of end pipes and welded flanges at both ends of bellows.

●Features

Standard expansion joint.

●Flange Rating

JIS, JPI, BS, DIN also available.

Double type is also available

●ベローズ寸法表 常温、0.1MPa

口径 Size (A)	山高 Height	ピッチ Pitch	厚さ Thickness	伸縮量 Axial movement	山数 No. of convolution	面間 Length
50	10	10	0.6	±5	6	160
				10	12	220
65	15	15	0.6	±8	4	160
				14	7	205
80	15	15	0.8	±5	4	160
				10	7	205
100	20	20	1	±5	3	160
				10	5	200
				15	7	240
				±10	3	220
125	30	30	1.2	15	4	250
				20	5	280
				25	7	340
				±10	3	220
150	30	30	1.2	15	4	250
				20	5	280
				25	7	340
				±10	3	240
200	30	30	1.2	15	4	270
				20	5	300
				25	7	360
				±10	3	240
250	30	30	1.2	15	4	270
				20	5	300
				25	7	360
				±10	3	240
300	30	30	1.2	15	4	270
				20	5	300
				25	7	360
				±10	3	240

EXPANSION JOINTS Z-15000